

North East Toilet Cubicles Ltd.

Tel: 01429 277500 Fax: 01429 868590

Email: info@netoiletcubicles.co.uk

Compact Flat Panel Vanity - Typical Frame Drawings - Details

The following drawings are provided as a guide only.

Frame cross section drawings are based on a Vanity 600mm deep x 800mm high.

Note - Frame sizes will change when different depths and/or heights are supplied, frame modifications may also need to be made to suit waste/soil pipes, plumbing or drains etc.

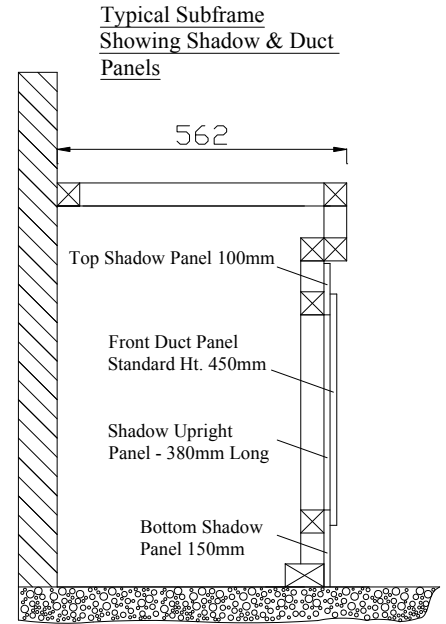
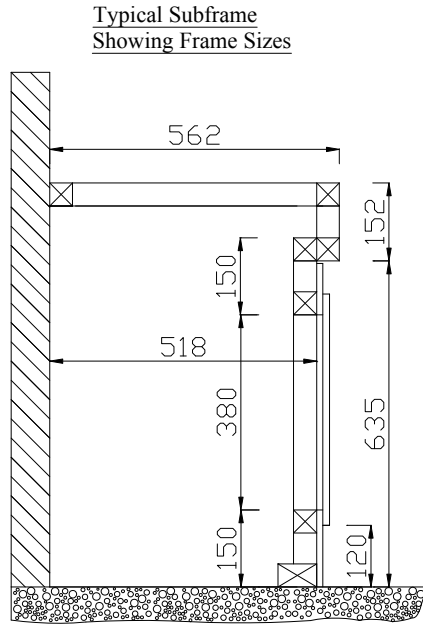
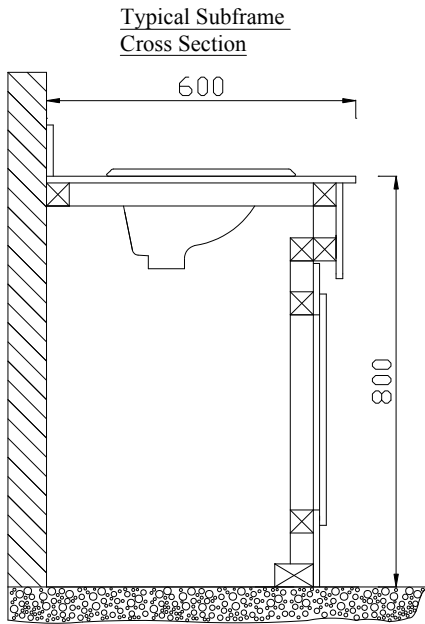

Information Provided for Guidance Only

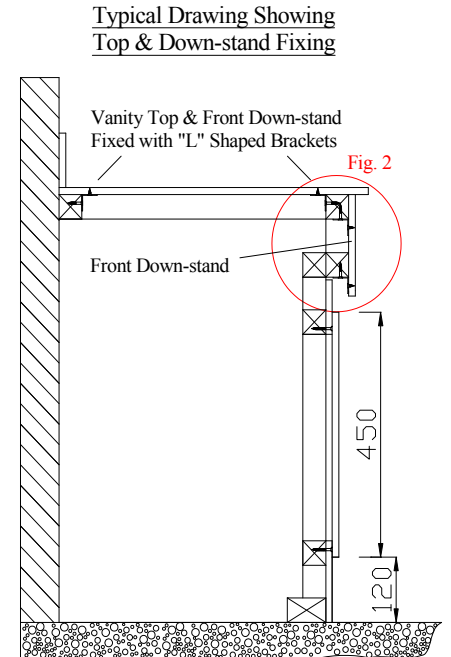
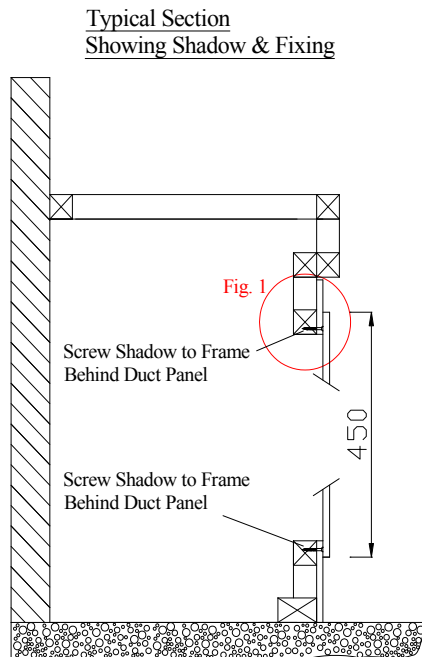
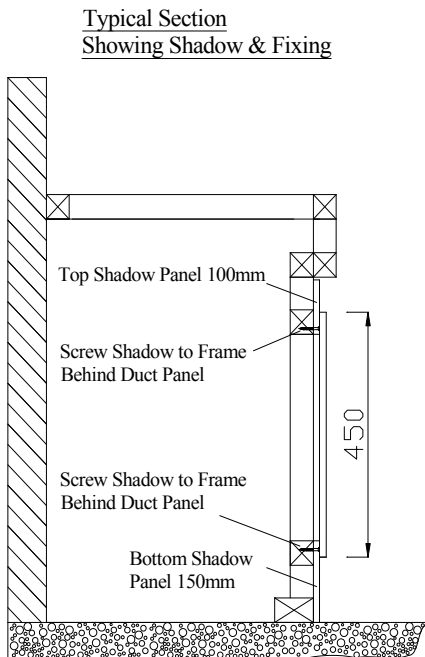

Information Provided for Guidance Only

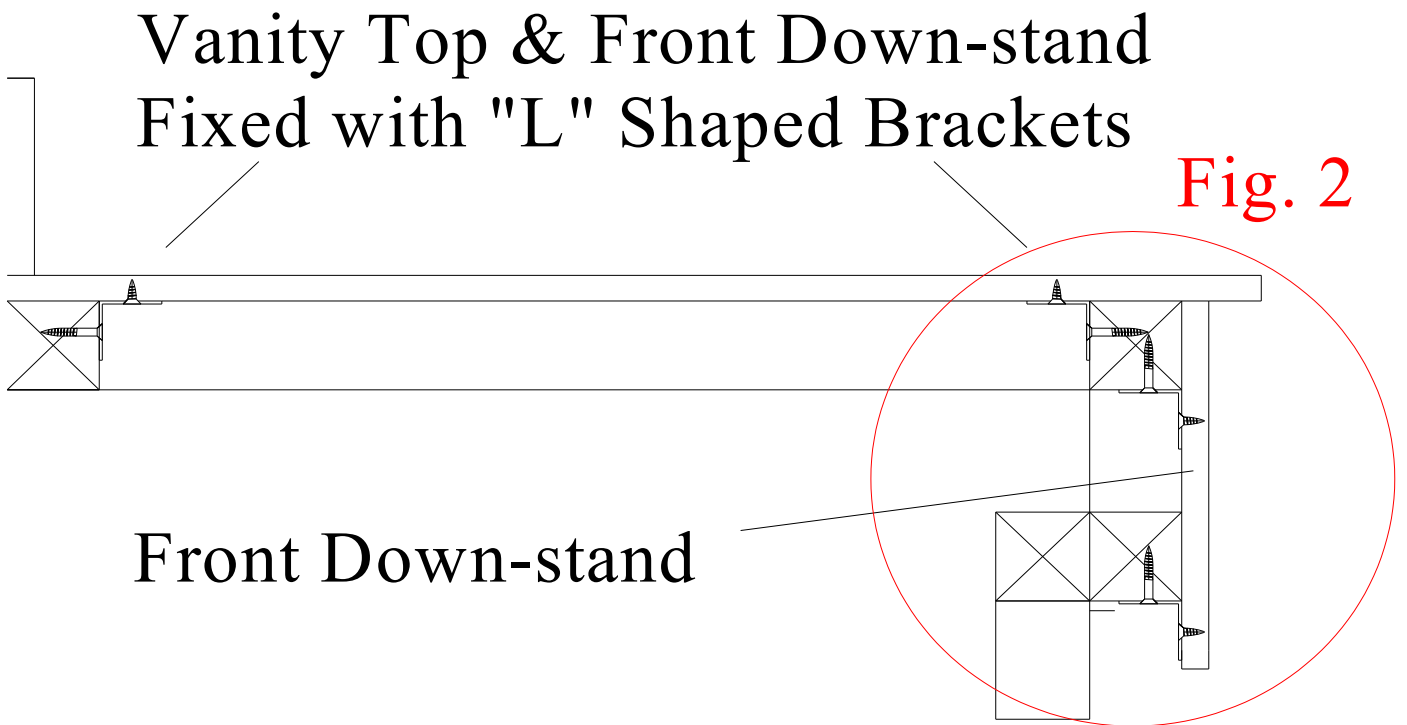
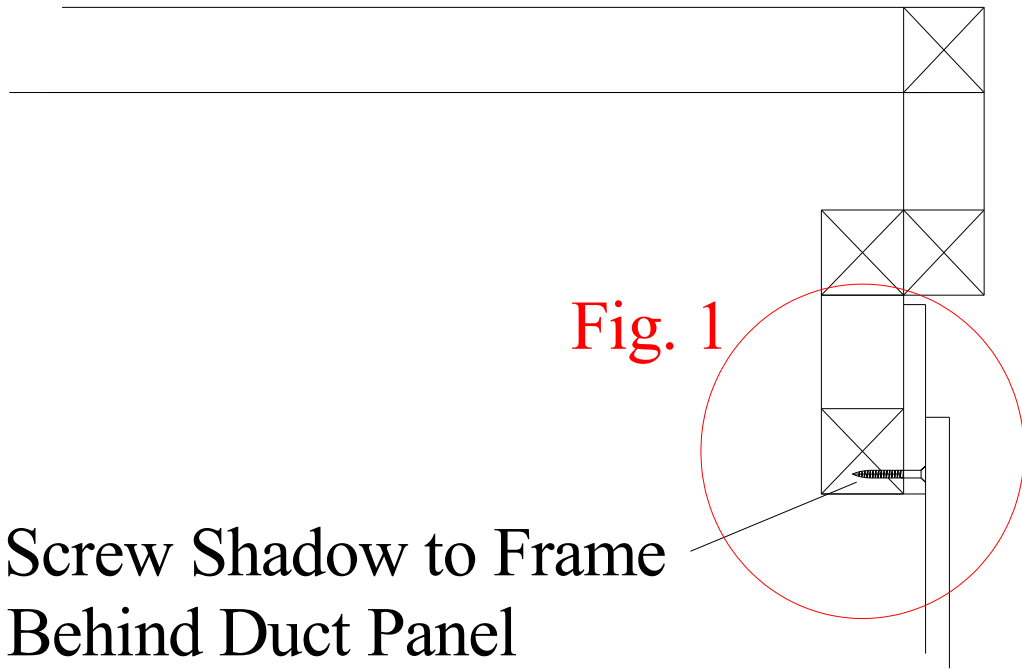

Vanity Frame / Shadow Floor Detail

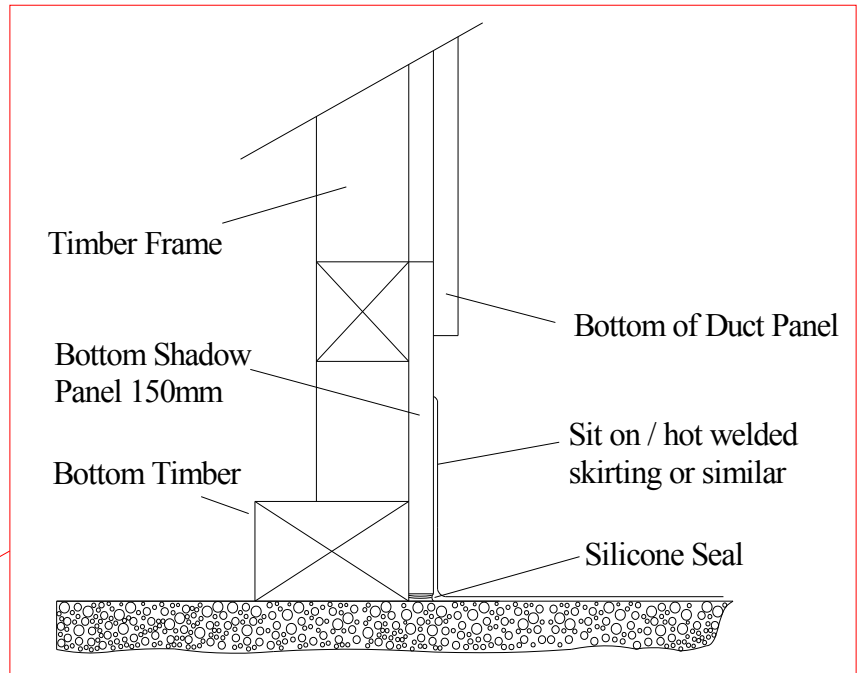
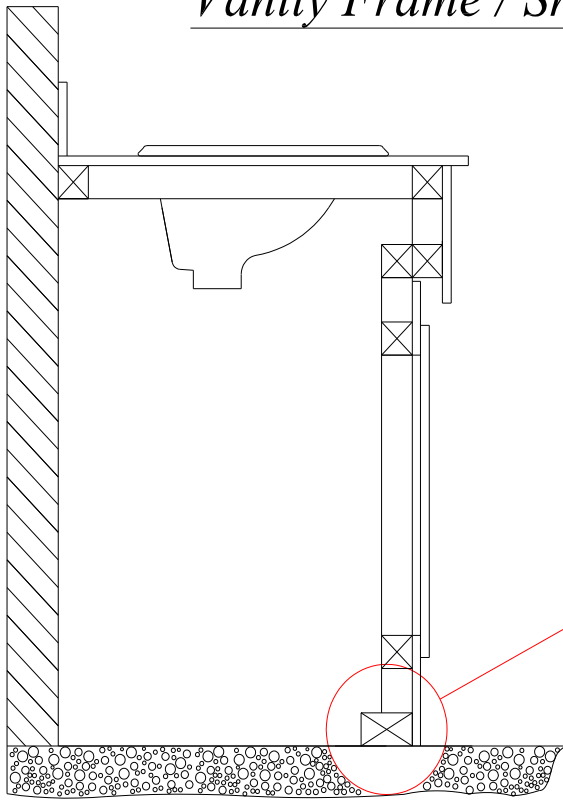

Panel Clip - Details

Typical drawing showing END / WALL shadow panel & duct panel clip arrangement

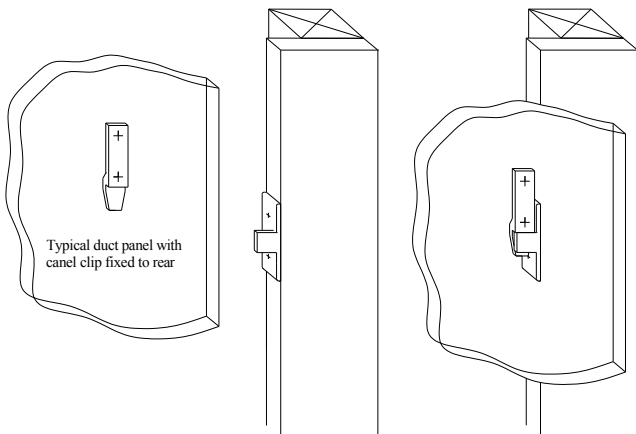

Typical drawing showing MIDDLE shadow panel & duct panel clip arrangement

